

# Eames Tables

Charles & Ray Eames, 1964/1968



The design story of the Eames Tables harks back to the 1940s, when Charles and Ray Eames developed the first versions of what later became the table base. These early designs, which already reflect the designer couple's characteristic method of thinking in systems, were suited for a variety of chairs and tables. The bases used today for the Eames Tables were created in the 1960s in conjunction with the development of the Soft Pad Chairs.

The Eames Tables are distinguished by their rational construction and aesthetic understatement. For decades they have facilitated communication, teamwork and interaction in offices, public spaces and homes. They meet today's requirements with intelligent power and data solutions and modern technologies such as wireless charging.

This table family comprises the large-surface Segmented Tables and the smaller Contract Tables. High-quality materials guarantee an unusually long product lifespan. All models are available with HPL tops, which have a distinctive rounded black plastic edge, or in a choice of wood veneers. The Eames Contract Tables are also offered with melamine-faced or solid core tops, the latter of which are suited for outdoor use.



## Charles & Ray Eames

Charles and Ray Eames are counted among the most important figures of twentieth-century design. Their work spans the fields of furniture design, filmmaking, photography and exhibition design. Vitra is the sole authorised manufacturer of Eames products for

Europe and the Middle East. When you own an Eames product made by Vitra, you know it is an original.

1	Eames Tables
2-5	Configurations
6-7	Table shapes
8-9	Electrification

10-11	Bases
12-13	Dimensions
13	Colours and materials

14-15	Eames Contract Tables
16-18	Eames Segmented Tables Meeting



**Eames Contract Table, square**, 750x750 mm, white melamine table top, legs and column powder-coated in white; chairs: .03

---



**Eames Contract Table, round**, Ø800 mm, white HPL table top with black edge, legs and column powder-coated in deep black; chairs: EFC

---



**Eames Contract Table, square, 750x750 mm, solid core table top with black edge, legs and column powder-coated in white and black, outdoor version; chair: Wire Chair**

---



**Eames Segmented Table Meeting, round, Ø1300 mm, 4 places, white HPL table top with black edge, legs with polished finish, column in basic dark, electrification: Punto Wireless Charging; chairs: .o3**

---



**Eames Segmented Table Meeting, round, Ø2000 mm, 6-8 places, table top in light oak veneer, legs with polished finish, column in basic dark, electrification: Punto Power/USB; chairs: EA 108**



**Eames Segmented Table Meeting, boat-shaped, 2000x1150 mm, 6 places, white HPL table top with black edge, legs and column chrome plated; chairs: EFC**



**Eames Segmented Table Meeting, boat-shaped, 3600x1300 mm, 10 places, table top in dark oak veneer, legs and column chrome-plated, electrification: Rotax; chairs: Softshell Chair**



**Eames Segmented Table Meeting, boat-shaped, 8000x2000 mm, 20+ places, table top in American walnut veneer, legs and column in deep black, electrification: Aletta; chairs: EA 208**

## TABLE SHAPES

**vitra.**

### Eames Contract Tables



- Ø 700 mm  
seats 2
- Ø 800 mm  
seats 3-4
- 750 x 750 mm  
seats 4

---

### Eames Segmented Tables Meeting



- Ø 1100 mm  
seats 4
- Ø 1300 mm  
seats 4-6
- Ø 2000 mm  
seats 6-8

---

### Eames Segmented Tables Meeting



- 2000 x 1150 mm  
seats 6
- 2800 x 1300 mm  
seats 8
- 3600 x 1300 mm  
seats 10

TABLE TOPS

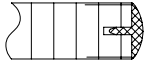

White HPL (25 mm) with black edge



White melamine-faced (25 mm) with smooth, straight plastic edge in white

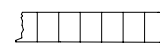

White solid core (12 mm) with black edge

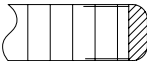

Light oak veneer (25 mm) with straight veneered edge

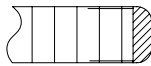

American walnut veneer (25 mm) with straight veneered edge



Dark oak veneer (25 mm) with straight veneered edge

	White HPL with black edge	White melamine with white plastic edge	White solid core with black edge*	Veneer, light oak	Veneer, American walnut	Veneer, dark oak
Contract Tables	●	●	●	●		●
Segmented Tables Meeting	●			●	●	●

\*suited for outdoor use

**New integrated electrification**

The base for Eames Segmented Tables has undergone complex revision to allow the elegant integration of modern power and data connections. The cables are fed discreetly

through the column so as not to affect the modularity of the sophisticated base, and the tables' visual appearance remains unaltered.



**Electrification example\***

- 1 Punto Wireless Charger
- 2 Set of electrification cables



Punto Power



Punto USB



Punto Wireless Charging

Only the spider has been unobtrusively expanded to incorporate the new Punto power module. Aletta or Rotax flaps can be

selected for the table top and equipped with the new Punto solution, which comes with power, USB or wireless charging options.



**Electrification example\***

- 1 Punto Power
- 2 Rotax
- 3 Aletta
- 4 Punto USB
- 5 Set of electrification cables

For further information regarding electrification or customer-specific solutions, please contact your Vitra sales representative.

\* Please observe local electrical regulations!



Rotax



Aletta



## BASES FOR CONTRACT TABLES, SIDE TABLES

**vitra.**



polished / basic dark



chrome-plated / basic dark



all chrome



powder-coated in deep black



powder-coated in white

## BASES FOR SEGMENTED TABLES MEETING



### Segmented base

consisting of legs, columns, spreaders and spiders for rectangular or boat-shaped table tops



chrome / basic dark



polished / basic dark



chrome / chrome



deep black

\*suited for outdoor use

## **BASES FOR SEGMENTED TABLES MEETING CUSTOMISED TABLE SYSTEMS**

The base construction of Eames Segmented Tables follows an ingenious concept that allows the modular combination of different components. The segmented base consists of legs, spreaders, columns and table top supports. The legs and spreader can be connected to the column at different angles,

creating modules suited to table tops of diverse shape and size. Tables of up to 10 m in length and 1.7 m in width can be created using the VCS Configurator.



### **Segmented base**

consisting of legs, columns, spreaders and spiders for large, customised table systems

---

**DIMENSIONS**

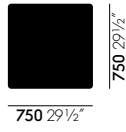

Eames Contract Table,  $\varnothing$   
700,  $\varnothing$  800

Eames Contract Table,  $\varnothing$   
750 x 750

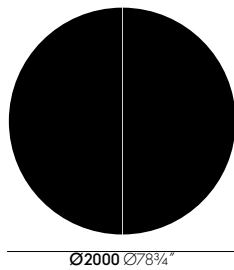
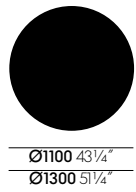
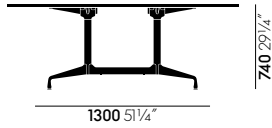

Eames Segmented Table,  
 $\varnothing$  1100,  $\varnothing$  1300

Eames Segmented Table Meeting,  
 $\varnothing$  2000

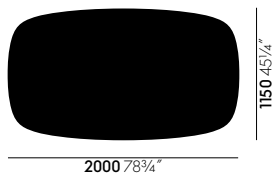
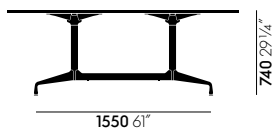

Eames Segmented Table Meeting,  
2000 x 1150

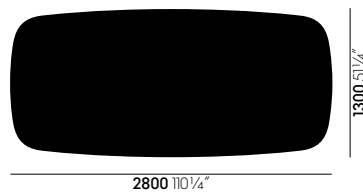
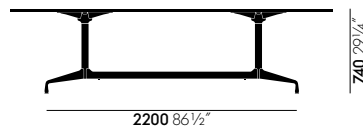

Eames Segmented Table Meeting,  
2800 x 1300

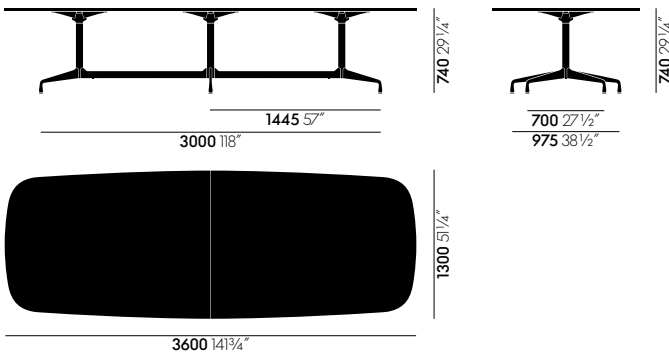

Eames Segmented Table Meeting,  
3600 x 1300

COLOURS AND MATERIALS

Eames Contract Tables

	<b>04</b> white powder-coated (textured)		<b>01</b> white (textured)
	<b>01</b> chrome		<b>12</b> white (smooth)
	<b>03</b> aluminium polished		<b>17</b> light oak
	<b>12</b> deep black powder-coated (textured)		<b>03</b> white (textured)
	<b>30</b> basic dark powder-coated (smooth)		<b>04</b> dark oak, with protective varnish

Base

Table top (Eames Contract Tables)

Eames Segmented Tables Meeting

	<b>01</b> chrome		<b>04</b> dark oak, with protective varnish
	<b>03</b> aluminium polished		<b>13</b> American walnut
	<b>30</b> basic dark powder-coated (smooth)		<b>12</b> white (smooth)
	<b>12</b> deep black powder-coated (textured)		<b>17</b> light oak

Base

Table top (Eames Segmented Tables)



The Vitra Configuration System (VCS) software contains comprehensive information on all Vitra products and assists you in the preparation of plans and offers. VCS is available through your sales representative or at [vcs@vitra.com](mailto:vcs@vitra.com).

Planning data, further information and illustrations can be found on the Vitra extranet for architects: [www.vitra.com/extranet](http://www.vitra.com/extranet). To verify your colour selections, please order the Vitra Colour and Material Sample Box.



# Eames Contract Tables

vitra.

Charles & Ray Eames, 1968



For the Contract Tables, Charles and Ray Eames developed a universal base, whose form strongly resembles the bases of the Soft Pad Group, while the structure evokes associations with the larger Eames Segmented Tables.

The Contract Tables make perfect small meeting tables and are also ideal as bistro tables for both indoor and outdoor use. They come with a round top in a choice of two sizes or as a square model.

## Materials

- **Table tops:** available in four materials: melamine faced white surface (25 mm) with smooth straight plastic edge in white; light or dark oak veneer (Europe) (25 mm) with straight veneer edge; solid core laminate in white (12 mm) with black edge; HPL (25 mm) with black edge.
- **Base:** stable pedestal base, four-star legs in die-cast aluminium. Available in four versions: base polished or chrome-plated with column in basic dark (RAL 9004), all chrome or all powder-coated (textured finish) in deep

black (RAL 9005) or white (RAL 9010). The height of the base including screw-in glides is 71 cm; the glides can be adjusted (max. extension 10 mm) for levelling on uneven floors.

- **Applications:** the powder-coated base can be paired with a solid core table top for outdoor use.

## DIMENSIONS



Ø700 Ø27 1/2"  
Ø800 Ø31 1/2"



750 29 1/2"

Eames Contract Table, ø  
700, ø 800

Eames Contract Table,  
750 x 750

## COLOURS AND MATERIALS

### Eames Contract Tables



**01**  
chrome



**03**  
aluminium  
polished

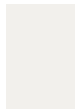

**04**  
white  
powder-coated  
(textured)



**12**  
deep black  
powder-coated  
(textured)



**30**  
basic dark  
powder-coated  
(smooth)

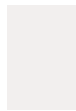

**01**  
white (textured)

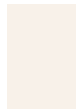

**12**  
white (smooth)

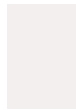

**03**  
white (textured)



**17**  
light oak



**04**  
dark oak, with  
protective  
varnish

Base

Table top (Eames Contract Tables)



The Vitra Configuration System (VCS) software contains comprehensive information on all Vitra products and assists you in the preparation of plans and offers. VCS is available through your sales representative or at [vcs@vitra.com](mailto:vcs@vitra.com).

Planning data, further information and illustrations can be found on the Vitra extranet for architects: [www.vitra.com/extranet](http://www.vitra.com/extranet). To verify your colour selections, please order the Vitra Colour and Material Sample Box.



# Eames Segmented Tables Meeting

**vitra.**

Charles & Ray Eames, 1964



In 1964, Charles and Ray Eames developed a system of base elements that enables many different table sizes and shapes, resulting in the elegant Eames Segmented Tables. Due to the versatility of this system, Vitra not only offers six standard table sizes but can also accommodate individual requirements and provide customised solutions.

The Segmented Tables can be equipped with power and data connections as well as wireless charging technology; cables are concealed in the base columns.

## Materials

- **Table top:** HPL high-pressure laminate surface (25 mm) with black edge; or oak veneer, light or dark (25 mm), with flat veneer edge.
- **Base:** components for segmented base include legs, spreader connectors, spreaders, columns and spiders. Legs and spreader connectors made of die-cast aluminium, polished, chrome finish or powder-coated; columns and spreaders made of steel, chrome-plated or powder-coated; spiders made of die-cast aluminium, powder-coated.

**DIMENSIONS**

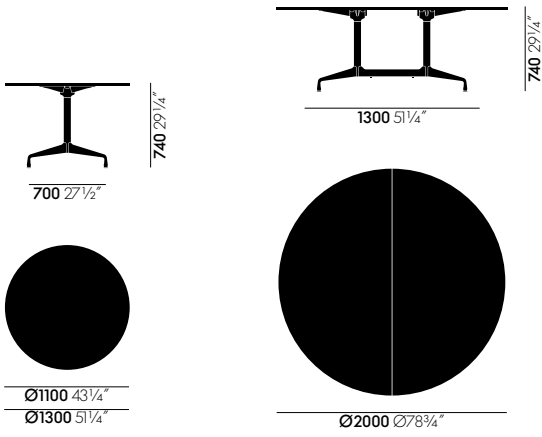

**Eames Segmented Table,**  
ø 1100, ø 1300

**Eames Segmented Table Meeting,**  
ø 2000

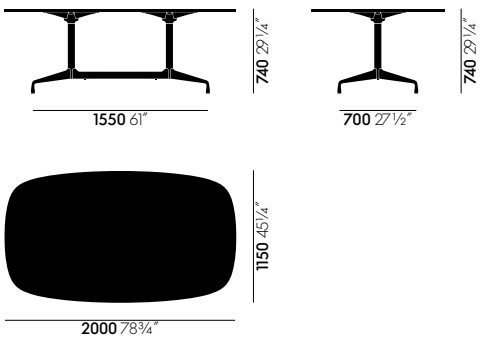

**Eames Segmented Table Meeting,**  
2000 x 1150

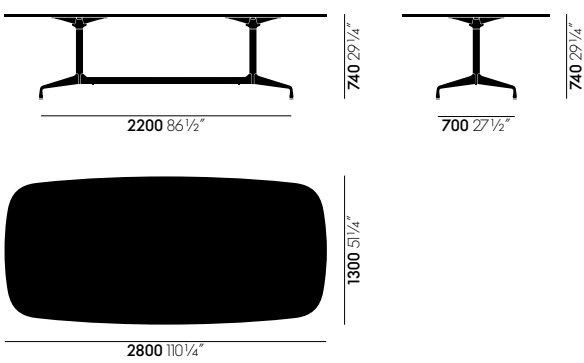

**Eames Segmented Table Meeting,**  
2800 x 1300



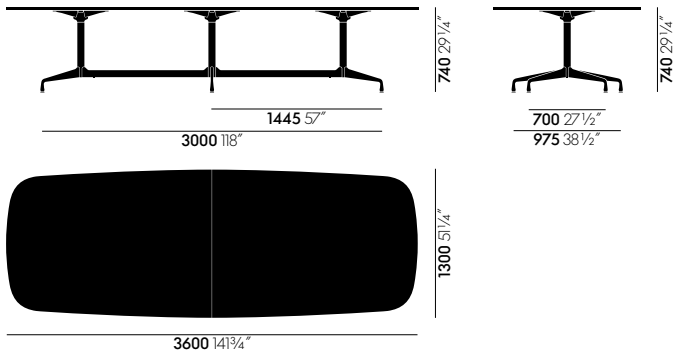

Eames Segmented Table Meeting,  
3600 x 1300

## COLOURS AND MATERIALS

### Eames Segmented Tables Meeting



Base

Table top (Eames Segmented Tables)



The Vitra Configuration System (VCS) software contains comprehensive information on all Vitra products and assists you in the preparation of plans and offers. VCS is available through your sales representative or at [vcs@vitra.com](mailto:vcs@vitra.com).

Planning data, further information and illustrations can be found on the Vitra extranet for architects: [www.vitra.com/extranet](http://www.vitra.com/extranet). To verify your colour selections, please order the Vitra Colour and Material Sample Box.

