

Storage Wall

Instruction for use
Gebrauchsanweisung
Mode d'emploi
Gebruiksaanwijzing
Istrucciones para el uso
Istruzioni per l'uso

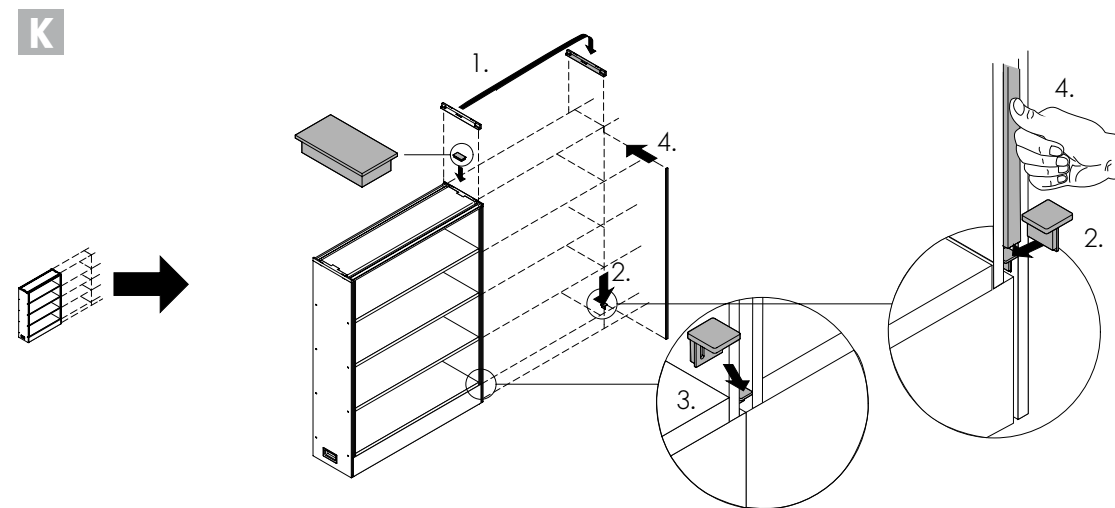
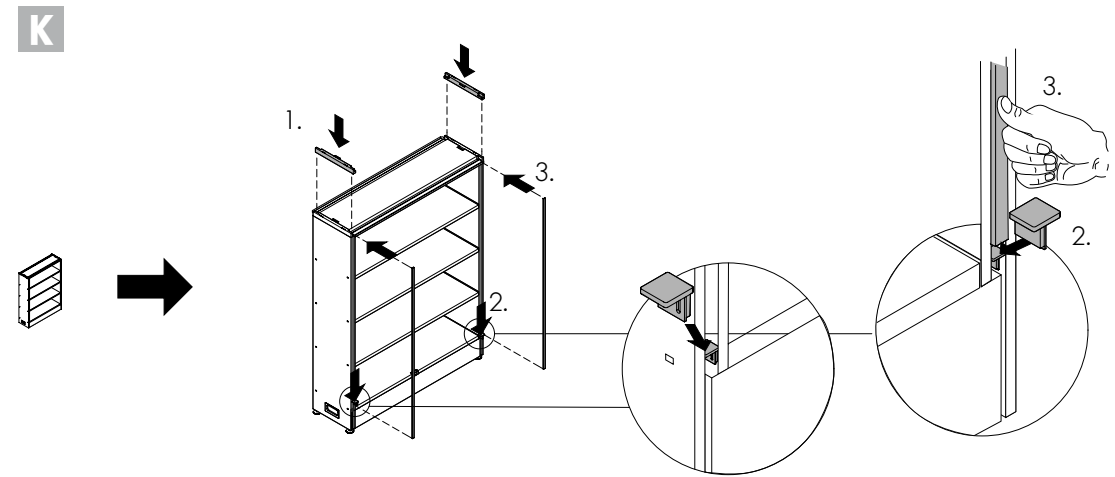
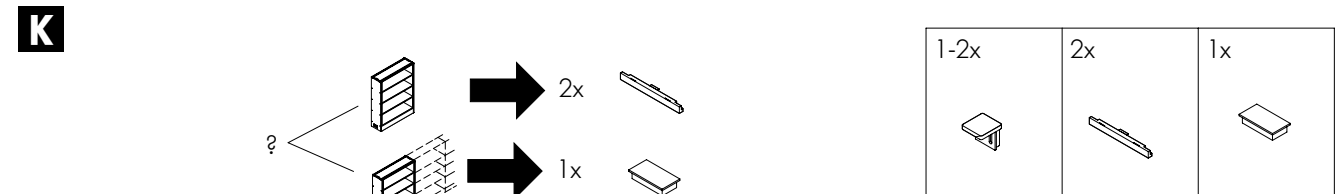
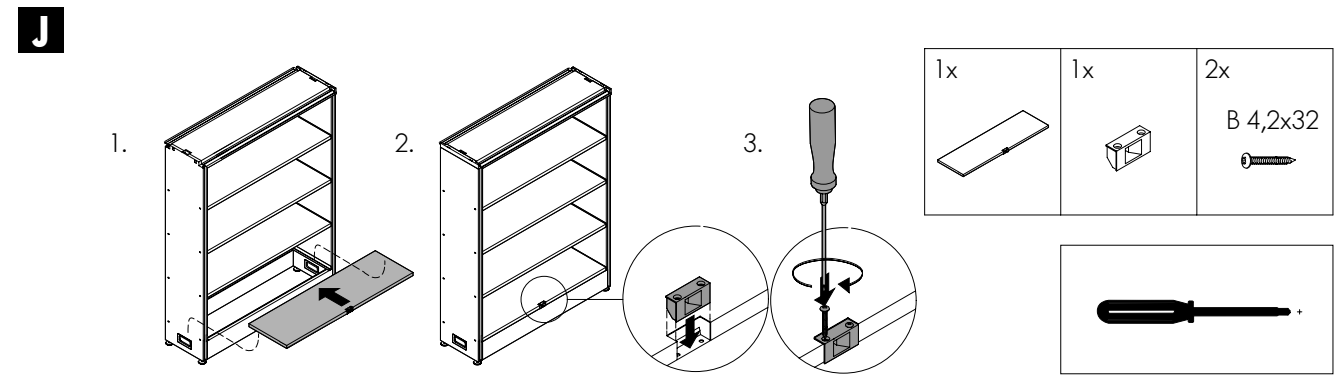
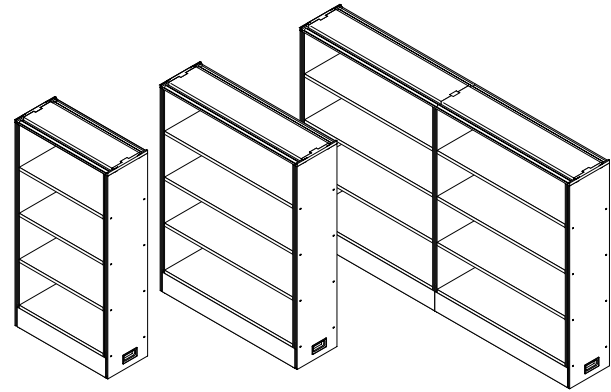

vitra.

vitra.

Vitra International AG, Birsfelden, CH | Vitra Ges.m.b.H., Wien, A | NV Vitra Belgium SA, Diegem, B | Vitra AG, Birsfelden, Showroom: Zürich, CH | Vitra koncept, s.r.o., Praha, CZ | Vitra GmbH, Weil am Rhein, Showroom: Frankfurt, D | Vitra Hispania S.A., Madrid, Showroom: Barcelona, E, Lisboa, P | Vitra, Paris, F | Vitra Ltd., London, GB | Vitra International AG, Budapest, HU | Vitra International AG, Bangalore/Mumbai/New Delhi, IN | Vitra, Mexico DF, MX | Vitra (Nederland) B.V., Ouderkerk aan de Amstel, NL | Vitra Scandinavia AS, Oslo, N | Vitra International AG, Warszawa, PL | Vitra Furniture (Shanghai) Co., Ltd., Shanghai, PRC | Vitra International AG, Moscow, RU | Vitra Furniture Pte. Ltd., Singapore | Vitra Inc., New York, Culver City, San Francisco, Chicago, USA | info@vitra.com | www.vitra.com

2009-B, Art.-No. 710 210 27

- EN** Read these instructions completely before using your new furniture and keep them close at hand for future reference. For service questions contact your authorized dealer or national affiliate. Your product should be used only whilst exercising the appropriate degree of care and in accordance with the manufacturer's instructions. A cupboard should therefore be used only as a cupboard. The use of your product for any purpose other than the one intended by the manufacturer, will result in an increased risk of accidents.
- DE** Lesen Sie diese Gebrauchsanweisung vor Gebrauch Ihres neuen Möbels genau durch und bewahren Sie diese zum späteren Nachschlagen sorgfältig auf. Für Service-Fragen wenden Sie sich an Ihren Fachhandelspartner oder Ihre Ländergesellschaften. Ihr Produkt darf unter Beachtung der allgemeinen Sorgfaltspflicht und bestimmungsgemäß nur als Schrank benutzt werden. Bei anderweitigem Einsatz besteht ein erhöhtes Unfallrisiko.
- FR** Veuillez étudier attentivement le mode d'emploi avant l'utilisation de votre nouveau meuble et conservez-le soigneusement pour toutes consultations ultérieures. Veuillez vous adresser pour toutes questions liées au service à votre concessionnaire spécialisé ou à une de vos agences nationales. Votre produit est destiné uniquement à l'utilisation en tant que armoire, conformément aux consignes de précaution et selon son usage destiné. Un risque d'accident élevé existe en cas d'utilisation inadéquate.
- NL** Lees deze handleiding vóór de inbedrijfstelling van uw nieuwe meubels zorgvuldig door en bewaar haar goed, zodat zij later steeds kan worden geraadpleegd. Neem bij technische vragen contact op met uw vakhandelspartner of met uw nationale maatschappij. Uw product mag alleen met inachtneming van de algemene zorgvuldigheidsplicht en reglementair alleen als kast gebruikt worden. Bij ander dan het beschreven gebruik bestaat een verhoogd ongevalrisico.
- ES** Lea usted con cuidado las presentes instrucciones de empleo antes de hacer uso de su nueva mueble y guárdelas en un lugar seguro con el fin de poder consultarlas posteriormente siempre que sea necesario. Para cuestiones de asistencia, diríjase a su establecimiento especializado a su sociedad nacional. El uso diligente y conforme a su finalidad de este producto impide que pueda utilizárselo de otra forma que como armario. De empleárselo con otra finalidad, se correrá un riesgo elevado de sufrir un accidente.
- IT** Leggere con attenzione e interamente queste istruzioni d'uso prima dell'utilizzo della vostra nuova mobile e conservarle con cura per successiva consultazione. Per richieste di assistenza rivolgersi al proprio rivenditore o ad aziende specializzate presenti sul territorio. Il vostro prodotto può essere utilizzato nel rispetto dell'obbligo generale di diligenza e conformemente alla prevista destinazione soltanto come armadio. Impieghi differenti comportano un elevato rischio di infortunio.

