

Soft Wait



Soft Wait

Edward Barber & Jay Osgerby, 2022

vitra.

vitra.

For decades now, Vitra has been exploring work trends and developing office concepts, creating comfortable and inviting home interiors and – since the production of the Eames Tandem Seating system for waiting areas – responding to the stringent requirements of public spaces. The boundaries between all of these areas of application are becoming

increasingly blurred: the workplace is acquiring a more casual and comfortable feel, the home office is becoming widely established, and more and more people are working while on the go. Vitra translates the consequences of these merging environments into functional products – such as Soft Wait, which Vitra developed together with the designers

Edward Barber and Jay Osgerby. The system has a modular design and not only allows multiple configurations but can also later be modified or expanded. Soft Wait can be assembled into linear and curved formations to make efficient use of the available space.



Edward Barber & Jay Osgerby

Edward Barber and Jay Osgerby studied architecture as fellow students at the Royal College of Art in London. Since that time, their collaborative work has probed the interface between industrial design, furniture design and architecture.



2-3	Soft Wait
4-11	Configurations Airport
12-15	Configurations Healthcare
16-19	Configurations Shared Space

20-21	Modular system
22-27	Module, Frame Structure, Format, Legs
28-30	Electrification

31	PRM seats
32	Upholstery
33	Surfaces and Colours
34-37	Dimensions

Airport



Airport



1. Airports:

Furniture in airport waiting lounges is subject to particularly stringent requirements: it must be extremely durable and adaptable to changing situations. At the same time, not only should it offer comfortable seating for travellers, but its visual design should contribute to a pleasant relaxing atmosphere.

Soft Wait has a modular structure that can be configured in diverse manners and provides inviting comfort even in the most hectic environments.



Double bench configurations with optional table modules and electrification between seats are ideal for high-capacity waiting areas.



Curved configurations combined with standard beam seating offer comfortable seat options, even for shorter waiting times – for example in shopping zones.

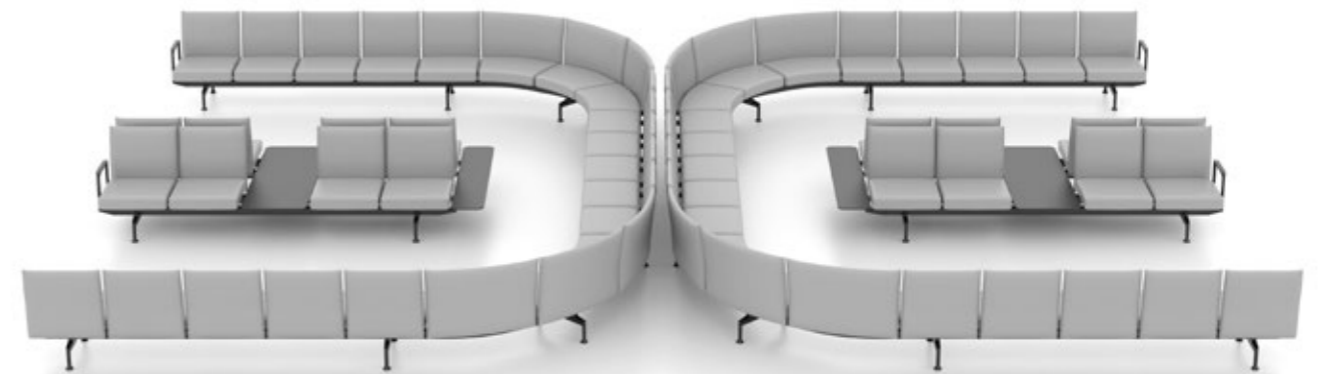

With concave modules, it is possible to plan installations that offer a sense of shelter in long corridors or larger interiors – combined with linear elements for optimal use of space.



Soft Wait can be used in creative configurations for lounges and waiting zones that offer comfortable relaxation, while demonstrating the necessary durability for busy terminals.



With convex and concave constellations, Soft Wait can be adapted to the floor layout. While making optimum use of space, the installations create visual variety and thereby improve the travel experience for passengers.

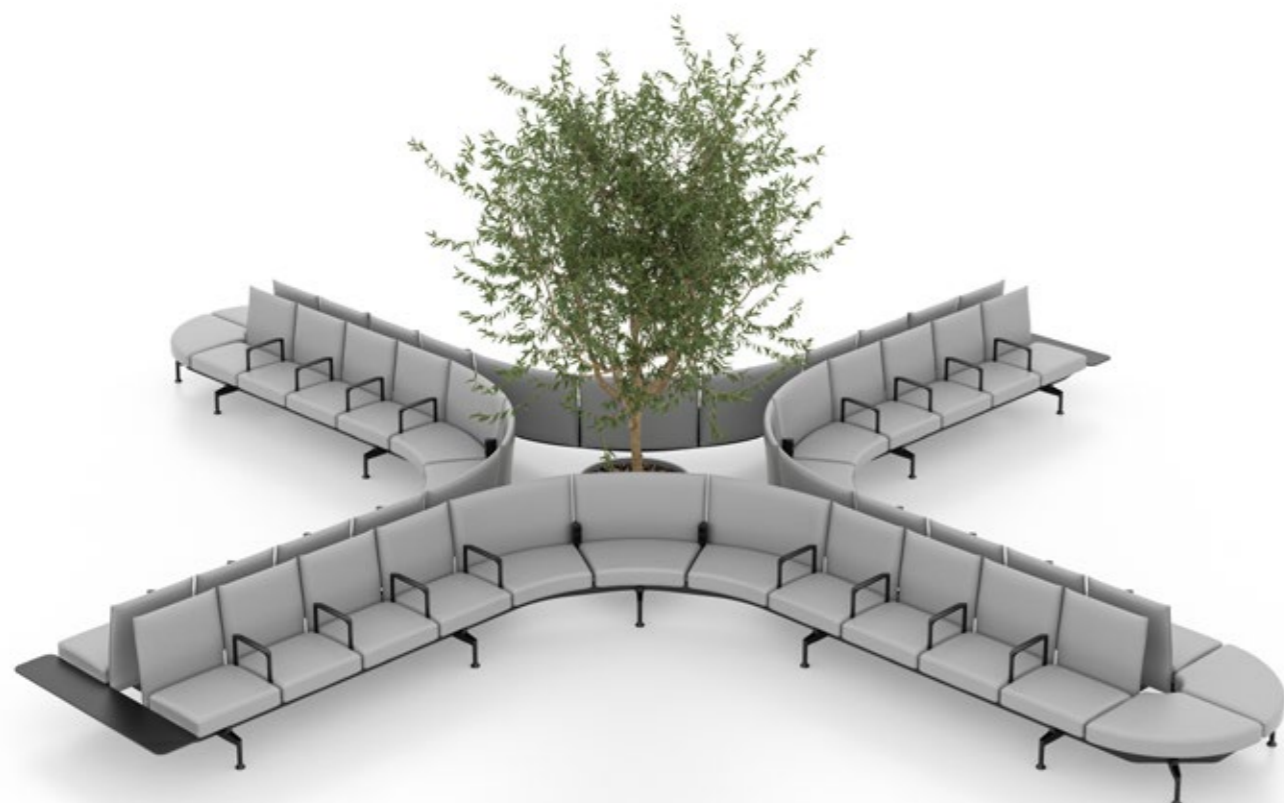

Even larger spaces can be modularly structured with curved or straight platforms.

Healthcare



2. Healthcare

Waiting is never pleasant but unfortunately unavoidable. The goal of interior designers is therefore to make this time more agreeable and productive, as well as to give these often anonymous environments a more inviting appeal. Soft Wait is a practical solution: the sofa-style system combines casual comfort and ergonomic seating, while also being suited to heavy use and the exacting demands of public spaces. Each detail is designed to be durable, easy to clean and simple to maintain: dirt cannot lodge itself anywhere. This makes Soft Wait also ideal for use in hospitals and medical practices.



Single and double benches for high-capacity primary and secondary waiting areas.



Inward and outward-facing curved configurations provide a dynamic visual distraction for both adults and children to ease the wait.



Inviting zones with straight and curved elements offer pleasant comfort and suit different patient needs.

Shared Space



3. Shared spaces

As museums, universities, concert halls and libraries are often bound by an overarching architectural concept, the integration of furnishings plays an important role. Soft Wait – also optionally available with electrification – has an understated aesthetic and therefore easily blends into the most diverse environments. The system offers pleasant comfort even for short periods of sitting.



Benches in seat or platform configurations, equipped with power connections, are ideal for short-term seating in public halls, main entrances and corridors.



S-shaped constellations with seats facing opposite directions offer a certain degree of privacy.



Combinations of curved and straight seat elements give users a sense of security, particularly in larger spaces such as lobbies or museum galleries.

Modular system

vitra.

vitra.

Soft Wait is a modular system for versatile configurations. The supporting unit consists of a frame construction on a bridge-like leg base, which can be endlessly extended as required with the aid of frame connectors. Linear frames form the base structure; concave and convex curves in 30° segments round off the system. Curved and linear frames can be combined. Outer armrests and single or double table tops are available as lateral end components. Single or double table modules can be inserted between two upholstered seat modules. All seat covers can be removed with low to moderate effort should the product require maintenance.

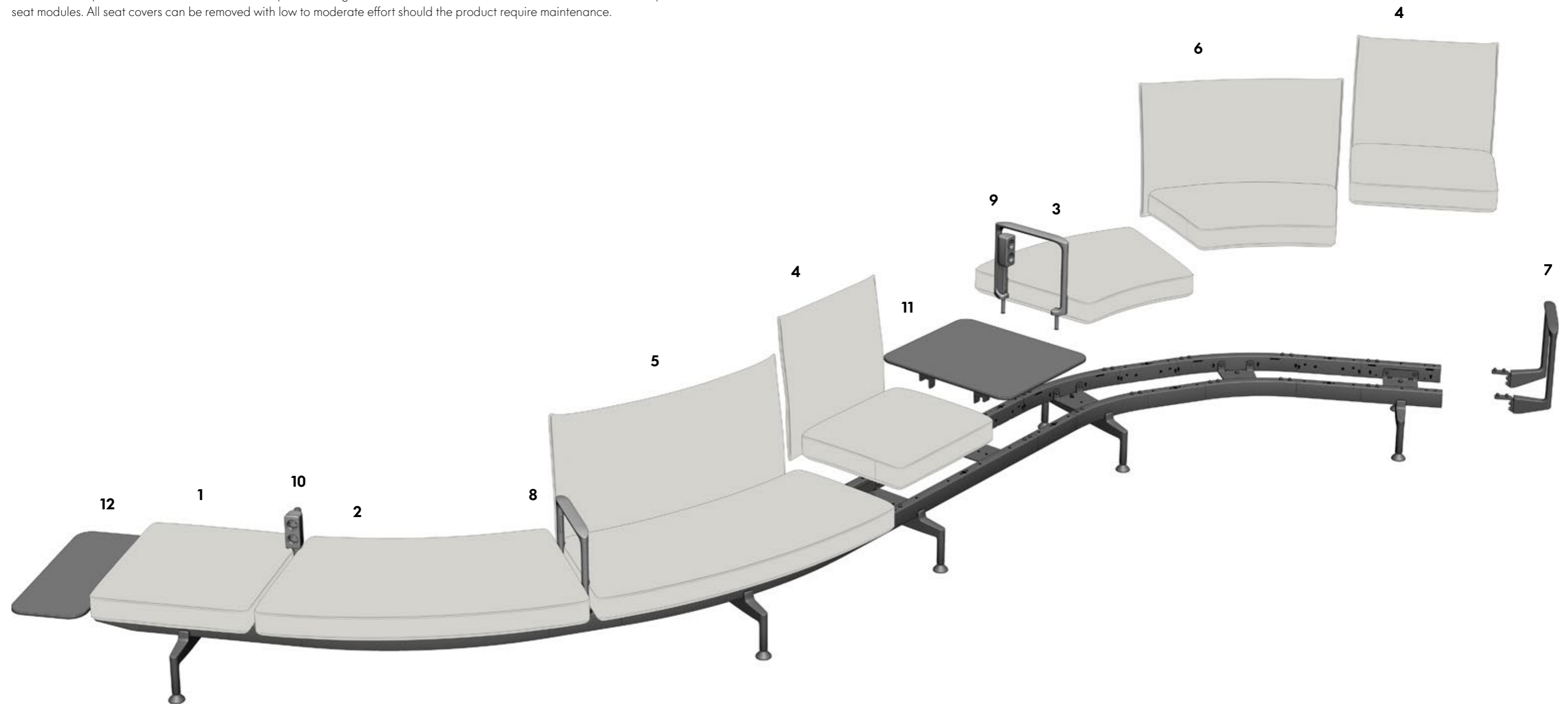

- 1 Platform module 60
- 2 Platform module 30° convex
- 3 Platform module 30° concave
- 4 Seat/back module 60
- 5 Seat/back module 30° convex

- 6 Seat/back module 30° concave
- 7 Outer armrest
- 8 Armrest
- 9 Armrest with electrification
- 10 Electrification holder

- 11 Table module 60 single
- 12 Side table single

Adaptability

The system has a modular design and not only allows multiple configurations but can also later be modified or expanded. The individual system modules adhere to a space-efficient 60 cm-format.

Soft Work makes it possible to combine comfortably upholstered seat modules with table modules to create diverse seating landscapes. Planning the configuration of seat and table modules determines the overall shape of the sofa setting.

Single bench

Single rows (single benches) can feature a mix of seat/back and platform modules. Armrests can be fitted to the frame at either end or between two upholstered seat modules.



Single bench with seat/back modules 60 including armrests



Single bench with platform modules 60 and seat/back modules 60 facing opposite directions can be interspersed with table elements and platforms to create spacing between users.



Single bench with platform modules 60

Double bench

With double rows (double benches), it is not possible to mix seat/back and platform modules, as they have different depths.



Double bench with seat/back modules 60



Double bench with platform modules 60

Frame assembly

Frame

The supporting unit consists of a frame construction on a bridge-like leg base, which can be endlessly extended as required with the aid of frame connectors. The frame supports the different upholstered seat and table modules, as well as all additional optional elements. The frame ends are open and must be covered with end caps, if they are not connected to anything else.



The frames for 1 and 2 modules are linking elements that can only be used in connection with other frames. They are not free-standing units. The smallest free-standing straight element is the frame for 3 modules. The longest continuous frame is the version for 5 modules. These can be endlessly extended or combined with curved elements with the aid of frame connectors.



A special frame for free-standing two-seaters is available separately and can be combined with other base elements using frame connectors.

30° curve and 90° curve

Frames for 30° curved modules are included with the upholstered seat module. The curved modules are individual linking elements, which must be joined using frame connectors. At least 3 curved modules have to be combined to achieve a stable curved free-standing configuration.

Frames for 90° curved modules come with legs and upholstered seats. The curved modules are individual linking elements, which must be joined using frame connectors.

They can be utilised as follows:

- with individual bench elements to form curved configurations
- as rounded ends for double-bench configurations
- as a stable, free-standing circular configuration when 4 curved modules are joined together



90° corner

The frame for linking two linear frames at a 90° angle is a component of the 90° corner table.



Format and footprints

Single bench, straight

The seat modules are designed as 60 cm-wide elements. There are seat/back modules and backless platform modules.

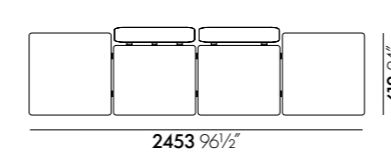

Single bench, curved

Concave and convex curves of 30° differ in radius. Seat/back and platform modules can be combined in single rows.

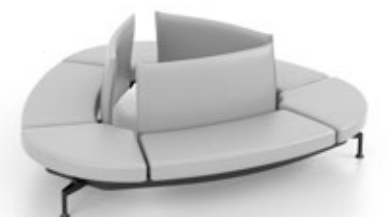
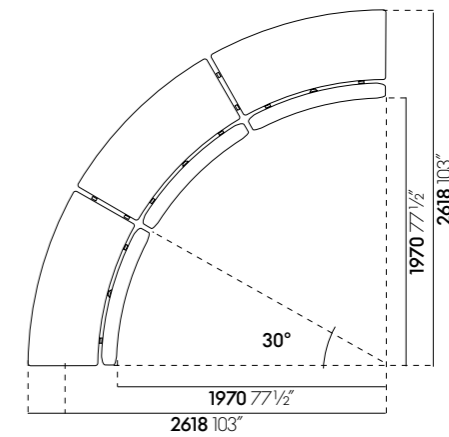
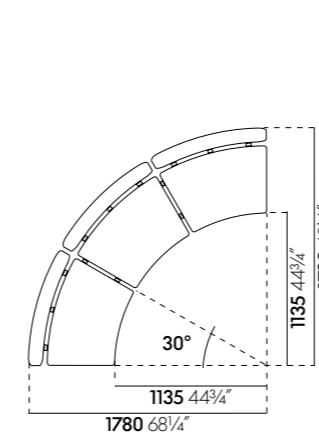

Format and footprints

Double bench, straight

The seat modules are designed as 60 cm-wide elements. There are seat/back modules and backless platform modules.



Double bench, curved

Concave and convex curves of 30° can be configured as circles or S-shaped installations to suit the needs and available space.

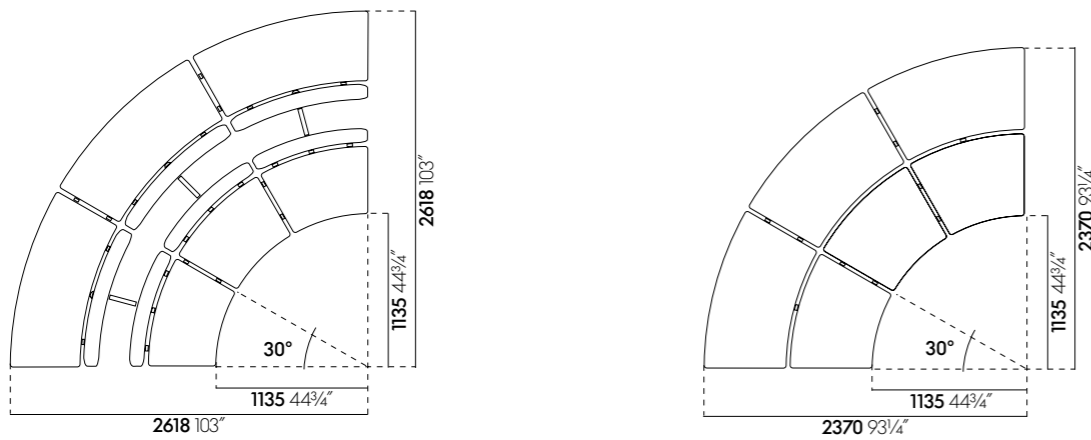

Legs

Linear configurations

The position of leg bases on the single bench, double bench and double platform should not exceed the maximum leg interval. The bridge-like leg bases are always mounted on the spacer plates of the frame and are therefore generally positioned under the centre of the seat or table module.

With an even number, it can be necessary to position the leg base between two modules for symmetrical reasons, using the 'frame connector for leg base'. No accessory can be added.

Maximum leg interval: linear frame: 2800 mm

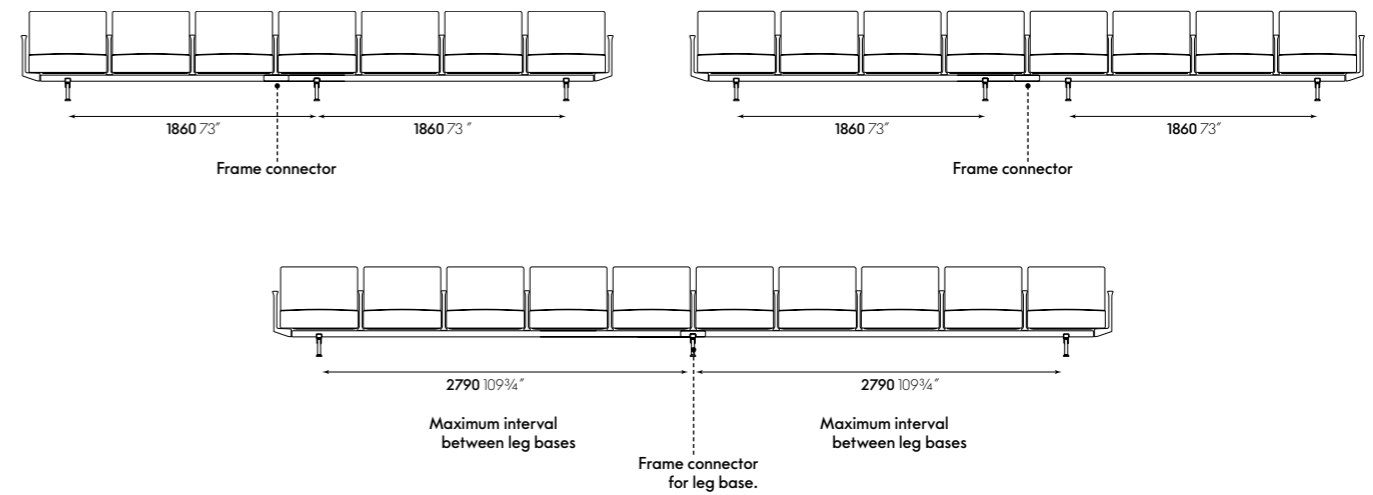

30° concave curves: one leg base on every second module (For a free-standing three-seat concave curve, each seat unit must have a leg base to prevent the element from tipping backwards.)

30° convex curves: one leg base on every module

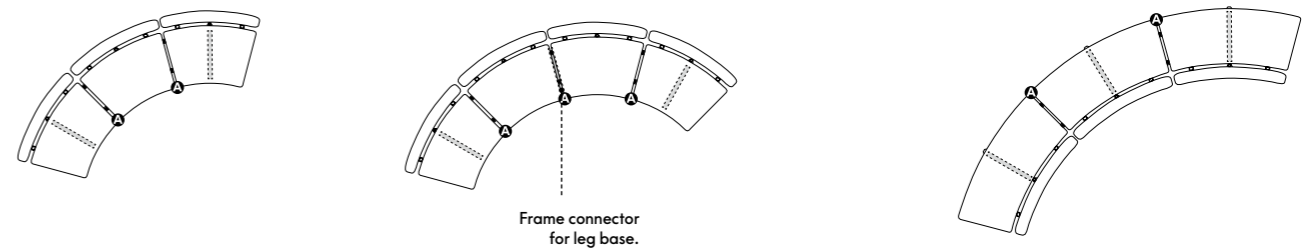

30° double curve

With curved double benches or platforms, it is sensible to mix leg bases for double benches and single benches.

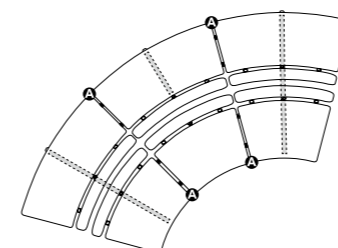

A: armrest or electrification holder.

For the electrification of Soft Wait, power cables in straight elements and connectors are conducted through cable channels, and in curved elements through cable baskets, which are suspended beneath the frame without the need for tools.



Electrification

- 1 Armrest without power connections
- 2 Armrest with electrification module
- 3 Electrification module
- 4 Distributor box
- 5 Cable basket 30°
- 6 Cable channel
- 7 Cable tube

Cables and accessories

Feed cables, connecting cables and distributors must be individually planned and ordered in accordance with the configuration.

The following articles are available for cable management:

Cable channel 60 for all straight frames and connectors. For curved elements, cable baskets can be attached as follows: frame for 1 module - 1 piece; frame for 2 modules - 3 pieces; frame for 3 modules - 5 pieces; frame for 4 modules - 7 pieces; frame for 5 modules - 9 pieces.

Armrests and power connections

vitra.



Outer armrest H 405 x W 165 x D 365 mm



Armrest H 335 x W 45 x D 365 mm
Can be retrofitted with electrification modules



Armrest H 335 x W 45 x D 365 mm
Armrest with power connections

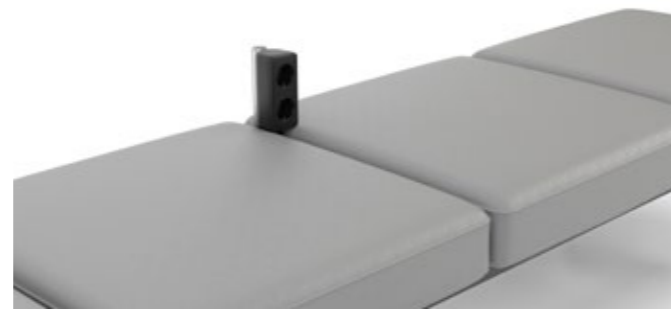

Electrification module for armrest and electrification holder
H 260 x W 60 x D 70 mm
Can be mounted on armrest or on electrification holder
Feed cables / connecting cables and connector must be ordered separately

PRM seats

vitra.



Soft Wait four-seater with two raised seats for people with reduced mobility and the elderly



Seat signage

Individual benches can be reserved for families or for persons with reduced mobility. The plaques can also accommodate other types of information such as advertising or numbering. In the case of individual raised seats, these seats can be clearly marked and distinguished from those at a standard height.

Upholstery

Upholstery structure

- Seat/back module:** seat and back joined by two back brackets (CDP aluminium).
- Platform module:** seat only.
- Seat:** straight module: support plate made of plastic (PA) in basic dark, quick fastener.
- Curved module:** support plate made of MDF, powder-coated in black. Quick fastener (PA) for tool-free attachment to frame profiles integrated in support plate. Overlying moulded foam (PUR), not glued. Cover secured to support plate with Keder edging; removable.
- Backrest:** plastic core (PA) enveloped in foam (PUR). Removable cover.
- Frame:** pair of profiles made of rectangular steel tubing (W 70 x H 40 mm), joined by spacer plates.
- Leg base:** made of die-cast aluminium, with plastic glides for levelling adjustment (max. 15 mm).

Useful facts about upholstery

Vitra has over fifty years of experience in the production of upholstered furniture. Premium materials, skilled craftsmanship and high quality standards at Vitra are a guarantee for long-lasting products. In Vitra's own test centre, our upholstered furnishings are regularly subjected to rigorous tests that far exceed common standards.

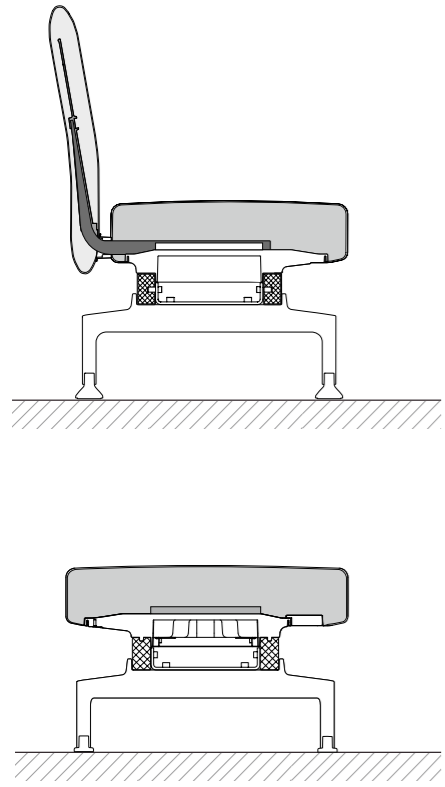

Surfaces and colours

Skai Pureto EN Heavy use, F60



Skai Pureto EN is a high-quality and durable PVC-free artificial leather. It mirrors the gentle texture of calfskin and has a similar feel to natural leather. Skai Pureto EN is a sustainable material, which is water-based as well as solvent-free. It is lightfast, robust and easy to clean, making it also suitable for areas of intensive use.

Skai Pureto EN is available in 7 colours.

Material	21% cotton, 60% polyurethane, 19% polyester
Weight	640 g/m ²
Width	142 cm
Abrasion resistance	100,000 Martindale
Fastness to light	Type 6
Fastness to rubbing	Grade 4-5 dry and wet



During processing, very fine creases appear on the surface of Skai Pureto EN. These are a result of the material properties and the manufacturing process, and are not grounds for claims or complaints.

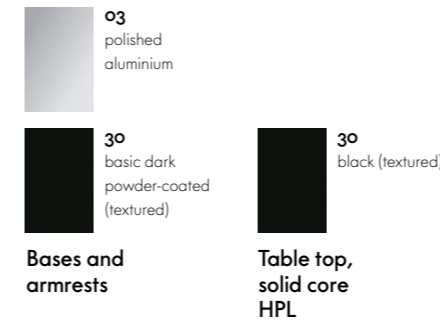

Bases and armrests

Table top, solid core HPL

Care instructions

Skai Pureto EN is a high-quality and durable PVC-free artificial leather. It mirrors the soft and smooth texture of calfskin and has a similar feel to natural leather. Skai Pureto EN is a sustainable material, which is water-based as well as solvent-free. It is lightfast, robust and easy to clean, making it also suitable for areas of intensive use. Skai Pureto EN is available in 7 colours.

Care instructions:

All Soft Wait covers are removable. Should you ever need to replace individual parts or covers due to wear and tear, please contact your local Vitra retailer.



Soft Wait Platform 3-Seater



Platform Module 90° curved

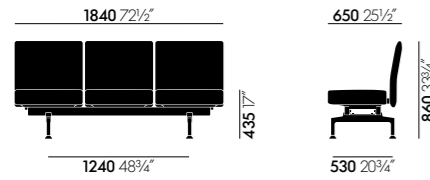

Soft Wait Seat/back module, 3-seater without armrest

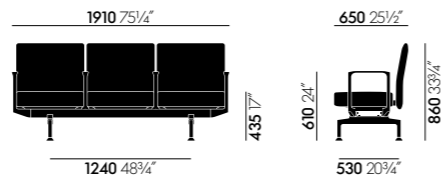

Soft Wait Single bench with armrest

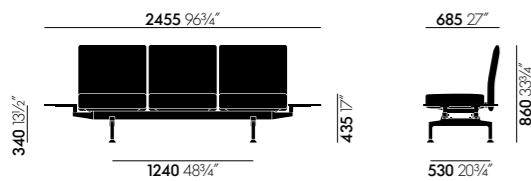

Soft Wait seat/back module, 3 seater with single side table

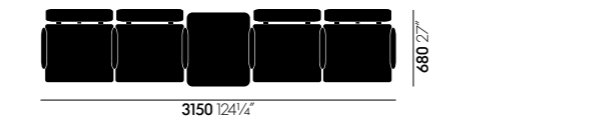
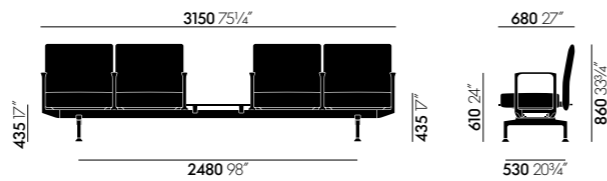

Soft Wait Seat/back module, 4-seater with table module

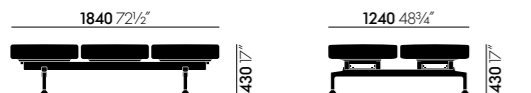

Soft Wait Platform 3-Seater double

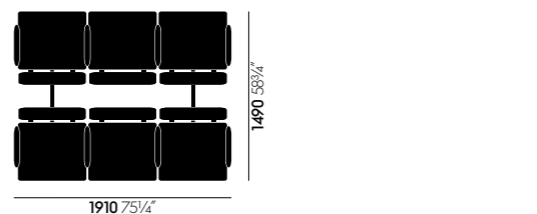
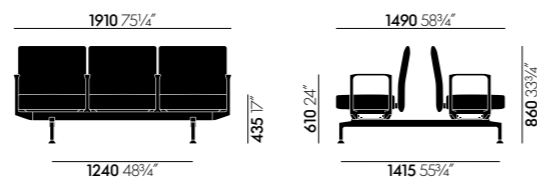

Soft Wait Seat/back module, 3-seater double

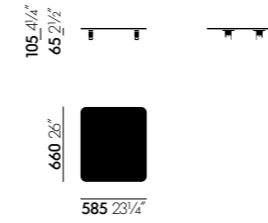

Soft Wait Table module 60 single

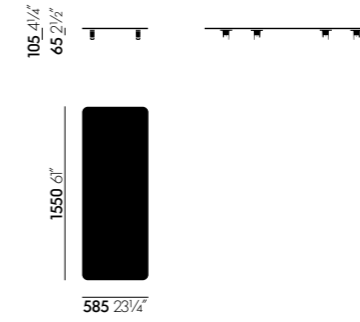

Soft Wait table module 60 for double benches

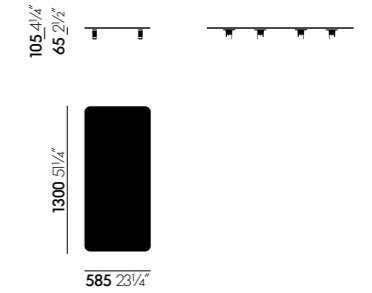

Soft Wait table module 60 for double platforms

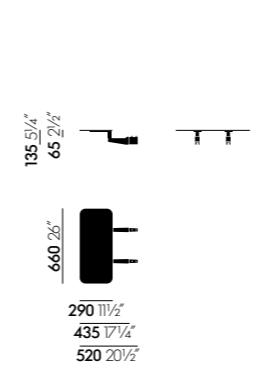

Soft Wait side table, single

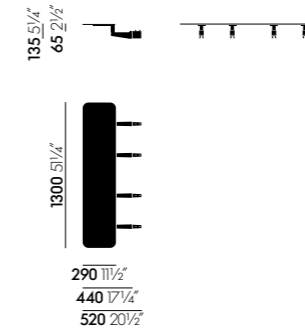

Soft Wait Table module 60 double for platform

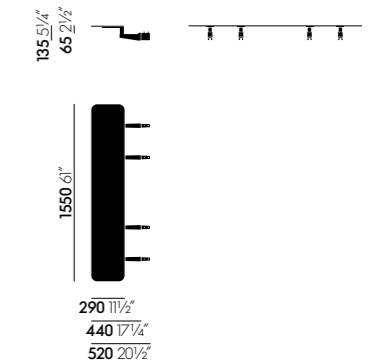

Soft Wait side table, double

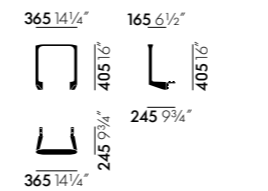

Soft Wait outer armrest

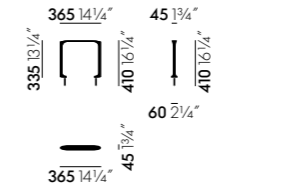

Soft Wait armrest

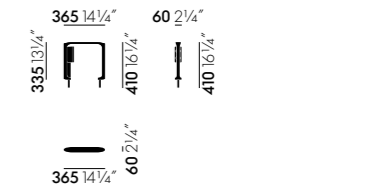

Soft Wait armrest with electrification

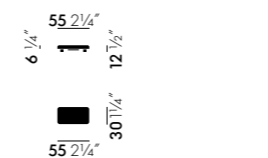

Soft Wait cover

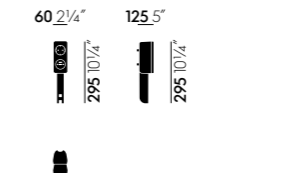

Soft Wait electrification module

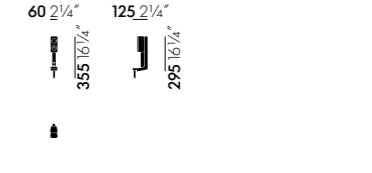

Soft Wait electrification holder with socket

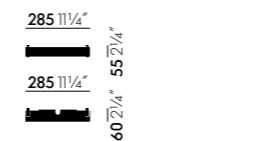

Soft Wait cable channel 60

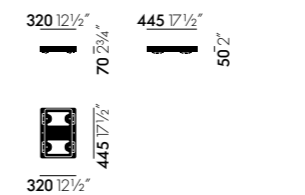

Soft Wait PRM Panel

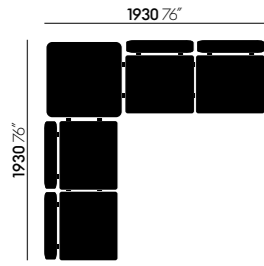

Soft Wait Sofa 4-Seater with corner table 90°

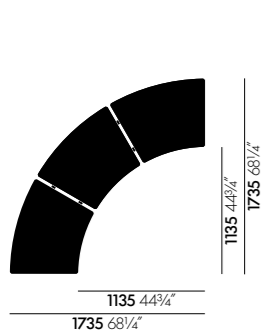

Soft Wait Platform quadrant, inner circle

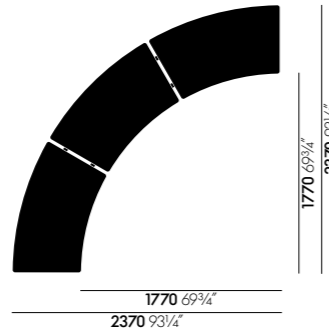

Soft Wait Platform 3-Seater, concave curve

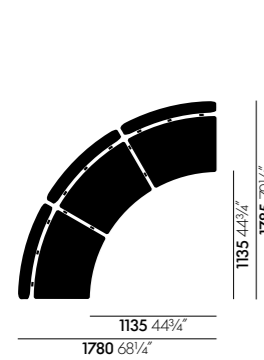

Soft Wait 3 seat/back modules 30°, concave curve 90°

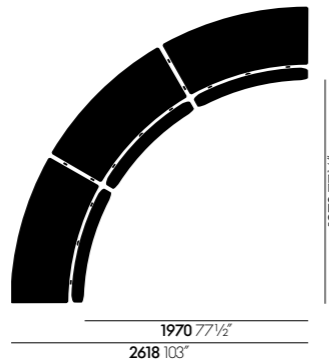

Soft Wait 3 seat/back modules 30°, convex curve 90°

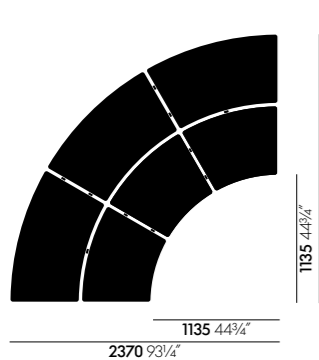

Soft Wait Platform double, concave/convex curve 90°



Soft Wait 3 seat/back modules 30° double row, concave/convex curve 90°

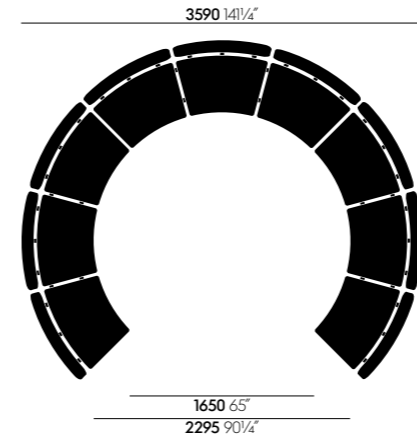

Soft Wait 9 seat/back modules 30°, concave curve 270°

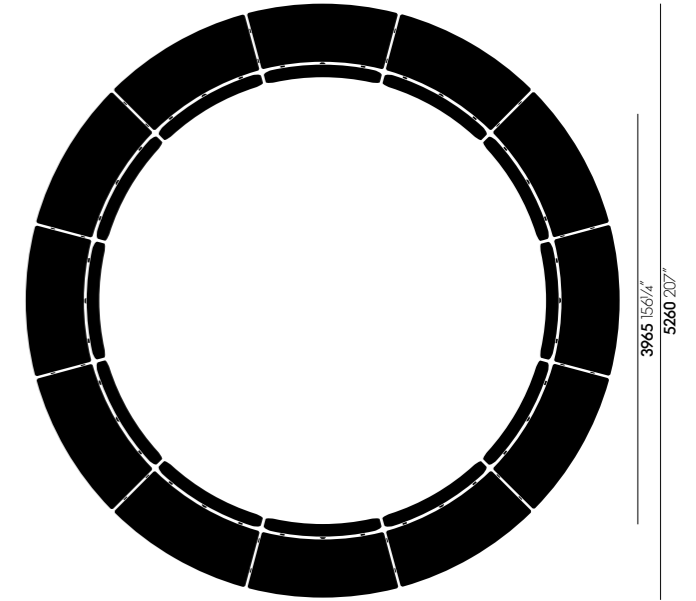

Soft Wait Seat/back module, 12-seater outer circle

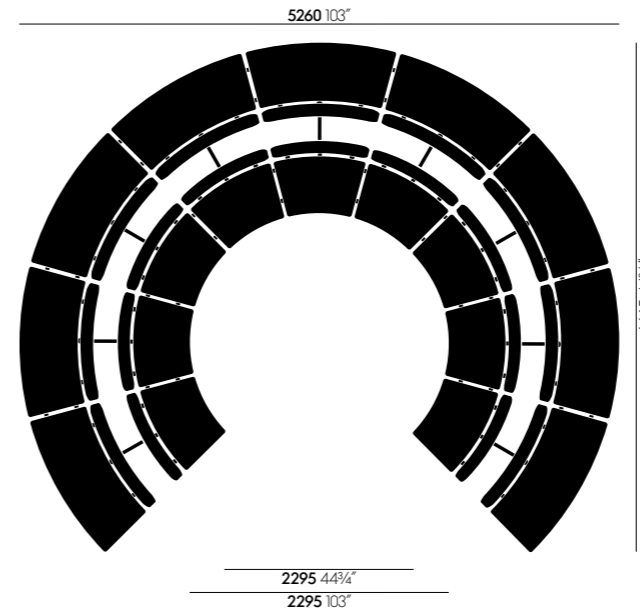

Soft Wait 9 seat/back modules 30° double row, concave/convex curve 270°

